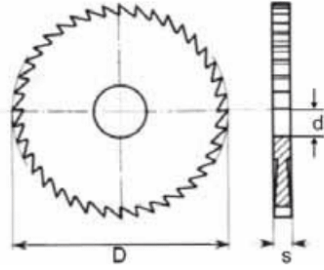
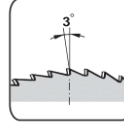

VHM

DIN
1837A

DxS (mm)	d (mm)	Z Diş sayısı
30x0,5	10	80
30x0,6	10	80
30x0,7	10	80
30x0,8	10	80
30x0,9	10	80
30x1,0	10	64
30x1,2	10	64
30x1,5	10	64
30x1,6	10	64
30x2,0	10	48
30x2,5	10	48
30x3,0	10	48
40x0,2	10	128
40x0,3	10	100
40x0,4	10	100
40x0,5	10	80
40x0,6	10	80
40x0,7	10	80
40x0,8	10	80
40x1,0	10	64
40x1,2	10	64
40x1,5	10	64
40x1,6	10	64
40x2,0	10	48
40x2,5	10	48

DxS (mm)	d (mm)	Z Diş sayısı
40x3,0	10	48
50x1,0	13	80
50x1,5	13	64
50x2,0	13	64
50x2,5	13	64
50x3,0	13	48
63x1,0	16	100
63x1,5	16	80
63x2,0	16	64
63x2,5	16	64
63x3,0	16	64
63x3,5	16	64
80x1,0	22	100
80x1,5	22	100
80x2,0	22	80
80x2,5	22	80
80x3,0	22	80
80x3,5	22	80
100x1,0	22	128
100x1,5	22	128
100x2,0	22	100
100x2,5	22	100
100x3,0	22	80
100x3,5	22	80

EL TESTERE LAMASI



BOY (mm)	EN (mm)	KALINLIK (mm)	Z Diş sayısı
300	13	0,60	18
300	13	0,60	24
300	25	0,65	18
300	25	0,65	24
300 Cr	25	0,80	18
300 Cr	25	0,80	24

MAKİNA TESTERE LAMASI



BOY (mm)	EN (mm)	KALINLIK (mm)	Z Diş sayısı
300	25	1,60	6
300	25	1,60	8
350	32	1,60	6
350	32	1,60	8
400	32	1,60	6
400	32	1,60	8
450	32	1,60	6
450	32	1,60	8
500	40	2,00	6
500	40	2,00	8
600	50	2,00	6
600	50	2,00	8
700	50	2,50	6
700	50	2,50	8

METAL DAİRE TESTERE

DIN 1837A HSS

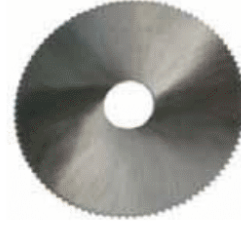
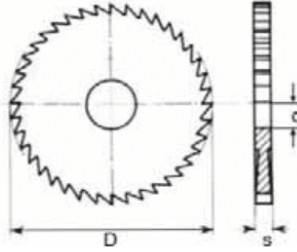
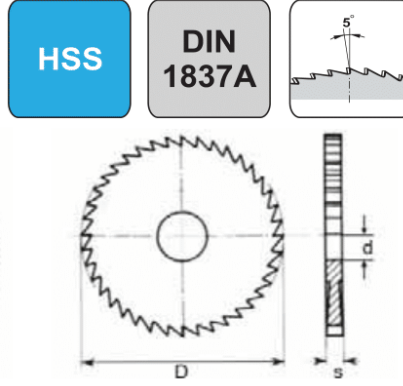

DxS (mm)	d (mm)	Z Diş sayısı
25X0,4	8	48
25X0,6	8	48
25X1,0	8	48
25X1,2	8	48
25X1,5	8	48
25X1,6	8	48
25X2,0	8	48
32X1,0	8	48
32X1,2	8	48
32X1,5	8	48
32X1,6	8	48
32X2,0	8	48
32X4,0	8	32
32X5,0	8	32
40X0,2	10	128/160
40X0,25	10	100/160
40X0,3	10	100/160
40X0,4	10	128/160
40X0,5	10	80
40X0,6	10	80
40X0,7	10	80
40X0,8	10	80
40X0,9	10	80
40X1,0	10	64
40X1,2	10	64
40X1,5	10	64
40X1,6	10	64
40X2,0	10	48
40X2,5	10	48
40X3,0	10	48
50X0,2	13	128/200
50X0,25	13	128/200
50X0,3	10/13	128/160/200
50X0,4	13	100/200
50X0,5	13	100/200
50X0,6	13	100
50X0,7	13	100
50X0,8	13	80
50X0,9	13	80
50X1,0	13	80
50X1,2	13	80

DxS (mm)	d (mm)	Z Diş sayısı
50X1,5	13	64
50X1,6	13	64
50X2,0	13	64
50X2,5	13	64
50X3,0	13	48
50X4,0	13	48
50X5,0	13	48
63X0,2	10/13/16	128/200
63X0,25	13/16	150/200
63X0,3	10/13/16	128/200
63X0,4	10/13/16	128/200
63X0,5	13/16	128/200
63X0,6	16	100
63X0,7	16	100
63X0,8	16	100
63X0,9	16	100
63X1,0	16	100
63X1,2	16	100
63X1,5	16	80
63X1,6	16	80
63X2,0	16	80
63X2,5	16	64
63X3,0	16	64
63X3,5	16	64
63X4,0	16	64
63X5,0	16	48
63X6,0	16	48
80X0,3	22	160
80X0,4	22	160
80X0,5	22	128
80X0,6	22	128
80X0,7	22	128
80X0,8	22	128
80X0,9	22	128
80X1,0	22	100
80X1,2	22	100
80X1,4	22	100
80X1,5	22	100
80X1,6	22	100
80X2,0	22	80
80X2,5	22	80

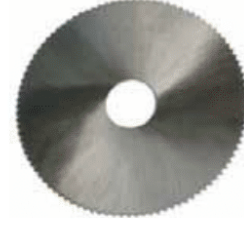
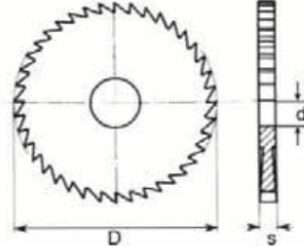
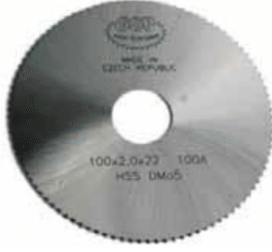
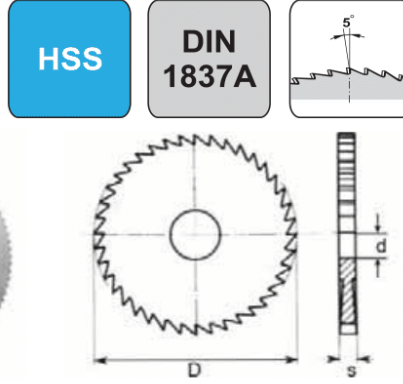

DxS (mm)	d (mm)	Z Diş sayısı
80X3,0	22	80
80X3,5	22	80
80X4,0	22	64
80x5,0	22	64
80x6,0	22	64
100X0,5	22	160
100X0,6	22	160
100X0,7	22	160
100X0,8	22	128
100X0,9	22	128
100X1,0	22	128
100X1,2	22	128
100X1,5	22	128
100X1,6	22	100
100X2,0	22	100
100X2,5	22	100
100X3,0	22	80
100X3,5	22	80
100X4,0	22	80
100X5,0	22	80
100X6,0	22	64
125X0,6	22/27	160
125X0,8	22/27	160
125X1,0	22/27	160
125X1,2	22/27	128
125X1,5	22/27	128
125X1,6	22/27	128
125X2,0	22/27	64/128
125X2,5	22/27	64/100
125X3,0	22/27	100
125X3,5	22/27	100
125X4,0	22/27	100
125X5,0	22/27	80
125X6,0	22/27	80
160X1,0	32	160

DxS (mm)	d (mm)	Z Diş sayısı
160X1,2	32	80/100/160
160X1,4	32	80
160X1,6	32	80/100/160
160X2,0	32	128
160X2,5	32	128
160X3,0	32	128
160X3,5	32	64/128
160X4,0	32	64/100
160X5,0	32	100
160X6,0	32	100
200X1,0	32	100/200
200X1,2	32	100/200
200X1,5	32	160/200
200X1,6	32	100/160/200
200X2,0	32	80/160
200X2,5	32	160
200X3,0	32	128
200X3,5	32	128
200X4,0	32	128
200X4,5	32	128
200X5,0	32	128
200X6,0	32	100
250X2,0	32	200
250X2,5	32	160/200
250X3,0	32	160/200
250X4,0	32	160
250X5,0	32	160
275X2,5	32	220
275X3,0	32	160
275X4,0	32	160
275X5,0	32	160
300X3,0	32	160
300X4,0	32	160
300X5,0	32	160